

REV.	DESCRIPTION	DATE	BY

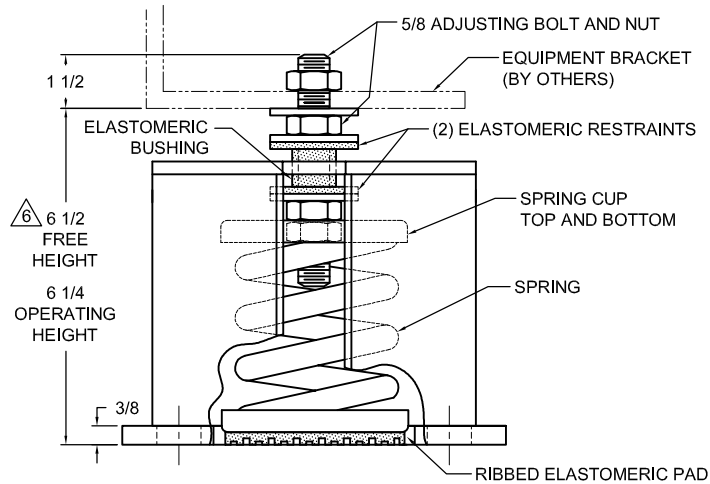
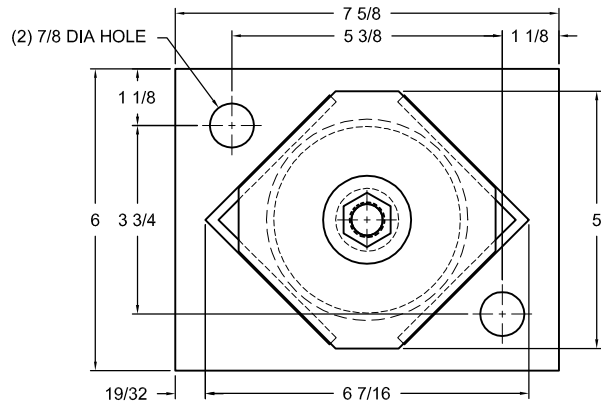

NOTES

1. ALL DIMENSIONS ARE IN INCHES. INTERPRET PER ANSI Y-14.
2. FINISH: HOUSING- ONE COAT BLACK PAINT, SPRING-POWDER COAT, HARDWARE- ZINC ELECTROPLATE.
3. INNER NESTED SPRING, WHEN USED, NOT SHOWN. SEE SPRING TABLE, NOTE 1.
4. ALL SPRINGS DESIGNED WITH 50% OVER-TRAVEL.
5. REFER TO TABLE ABOVE FOR ALLOWABLE HORIZONTAL AND VERTICAL G RATINGS. SEE TABLE NOTE 2.
6. PRIOR TO MOUNTING EQUIPMENT, THE INTERNAL VERTICAL RESTRAINT WILL BE AGAINST THE HOUSING TOP PLATE AND THE ADJUSTING NUT WILL BE 1/4" ABOVE THE BLOCK AT THE "FREE HEIGHT." WHEN THE EQUIPMENT IS MOUNTED, THE SPRING WILL DEPRESS AND REST ON THE SHIM AT THE "OPERATING HEIGHT."
7. RATED DEFLECTIONS ARE WITHIN 25% OF NOMINAL. HIGHER DEFLECTIONS ARE ALLOWED IF THEY MEET SPECIFICATIONS.

TYPE AMSR-1E SEISMICALLY RESTRAINED SPRING VIBRATION ISOLATORS						
MODEL	RATED LOAD (LBS)	RATED DEFLECTION (IN)	SPRING RATE (L.B/IN)	SPRING COLOR CODE	ALLOWABLE G RATING ²	
					HORIZONTAL	VERTICAL
AMSR-1E-195	195	1.95	100	DK BLUE	7.2	10.1
AMSR-1E-400	400	1.32	303	BLACK	3.5	4.9
AMSR-1E-530N ¹	530	1.17	453	BLACK/ DK BLUE	2.6	3.7
AMSR-1E-650	650	1.05	620	RED	2.2	3.0
AMSR-1E-825N ¹	825	1.07	770	RED/ DK BLUE	1.7	2.4
AMSR-1E-1000	1000	1.00	1000	TAN	1.4	2.5
AMSR-1E-1200N ¹	1200	1.04	1150	TAN/ DK BLUE	1.2	2.1
AMSR-1E-1400	1400	1.00	1400	PINK	1.0	1.8
AMSR-1E-1700N ¹	1700	1.10	1550	PINK/ DK BLUE	0.8	1.4
AMSR-1E-2000	2000	1.11	1800	WHITE	0.7	1.2
AMSR-1E-2330N ¹	2330	1.11	2100	WHITE/ RED	0.6	1.1
AMSR-1E-2575N ¹	2575	1.11	2313	WHITE/DK PURPLE	0.5	1.0
AMSR-1E-2990N ¹	2990	1.12	2681	WHITE/DK GREEN	0.5	0.8
AMSR-1E-3250N ¹	3250	1.04	3127	WHITE/GRAY	0.4	0.8

TABLE NOTES:
 1. TWO NESTED SPRINGS YIELD THIS LOAD.
 2. ALL ALLOWABLE G RATINGS ARE BASED ON HLTI KWIKBOLT TZ WEDGE ANCHORS (OR EQUAL) IN STONE AND AGGREGATE CONCRETE (F_c=3000 PSI).

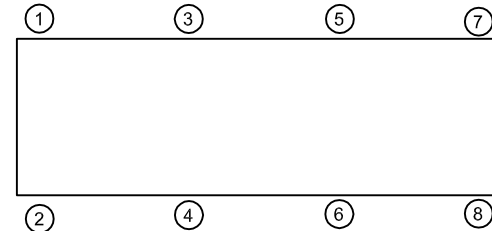

ISOLATOR SELECTIONS	
LOC 1:	LOC 2:
LOC 3:	LOC 4:
LOC 5:	LOC 6:
LOC 7:	LOC 8:
CUSTOMER EQPT. TAG:	

NOTE: MATERIAL SHOWN IS FOR (1) SET.

OTHER MATERIALS, COMPOUNDS, OR FINISHES WITH EQUAL OR SUPERIOR PROPERTIES MAY BE SUBSTITUTED AS THEY BECOME AVAILABLE.

CERTIFIED FOR:

JOB NAME: _____
 CUSTOMER: _____
 CUSTOMER P.O.: _____
 SALES ORDER: _____

**MODEL AMSR-1E 195-3250 LBS.
 SEISMIC ISOLATORS
 1 INCH DEFLECTION**



THE VMC GROUP
 The Power of Together
 Bloomington, NJ 07403
 Houston, TX 77041

SCALE:
 NONE

SHEET: _____



DRAWING NO.: _____

REVISION: _____

REV.	DESCRIPTION	DATE	BY

READ INSTRUCTIONS IN THEIR ENTIRETY BEFORE BEGINNING.

- ISOLATORS ARE SHIPPED FULLY ASSEMBLED AND ARE TO BE SPACED AND ARRANGED IN ACCORDANCE WITH INSTALLATION DRAWINGS OR AS OTHERWISE RECOMMENDED.
- SET ISOLATORS ON FLOOR OR SUB-BASE, ENSURING THAT ALL ISOLATOR CENTERLINES MATCH THE EQUIPMENT MOUNTING HOLES OR SPACE AND ARRANGE ISOLATORS IN ACCORDANCE WITH THE INSTALLATION DRAWING. SHIM OR GROUT AS REQUIRED LEVELING ALL ISOLATOR BASE PLATES AT THE SAME ELEVATION (1/4" MAXIMUM DIFFERENCE IN ELEVATION CAN BE TOLERATED). ISOLATOR BASE MUST REST ON A FLAT SURFACE.
- PRIOR TO INSTALLING EQUIPMENT ON THE ISOLATOR, HOUSING WILL BE ELEVATED SLIGHTLY ABOVE THE FINISHED SLAB. ANCHOR DOWN ISOLATOR'S USING BASE PLATE THRU HOLES "H". PULL DOWN ISOLATOR HOUSING USING PRESET ANCHOR BOLTS BY OTHERS UNTIL ISOLATOR BASE PLATE "E" IS FIRMLY AGAINST THE SLAB. THIS WILL PRELOAD THE SPRING WITHIN THE HOUSING AND PUSH THE INTERNAL STOP "A" AGAINST THE HOUSING TOP PLATE.
- REMOVE EQUIPMENT ATTACHMENT NUT "B" ON ISOLATOR STUD "C" AND PLACE EQUIPMENT ON ISOLATOR'S WASHER "F". THE EQUIPMENT WEIGHT WILL COMPRESS THE SPRING INSIDE THE HOUSING.
- TURN THE ADJUSTING NUT "D" UNDER THE WASHER COUNTER-CLOCKWISE TO COMPRESS THE SPRING. WHEN THE LOAD IS EQUALIZED, TURNING THE NUT WILL RAISE THE EQUIPMENT UNTIL THE INTERNAL GAP "G-1" IS APPROXIMATELY EQUAL TO THE EXTERNAL GAP "G-2". (I.E. THE EQUIPMENT CAN MOVE UP OR DOWN, THE SAME DISTANCE IN A SEISMIC EVENT).
- THE ADJUSTING PROCESS SHOULD BE DONE GRADUALLY ON ALL ISOLATORS.
- REPLACE ISOLATOR ATTACHMENT NUTS "B" ON ADJUSTING BOLTS "C" TO SECURE MACHINE LEGS TO ISOLATORS. HAND TIGHTEN WHERE THERE IS FIRM CONTACT BETWEEN THE NUT AND EQUIPMENT. (HAND TOOLS MAY BE USED.) THEN TIGHTEN THE NUT AN ADDITIONAL 1/3 TURN.

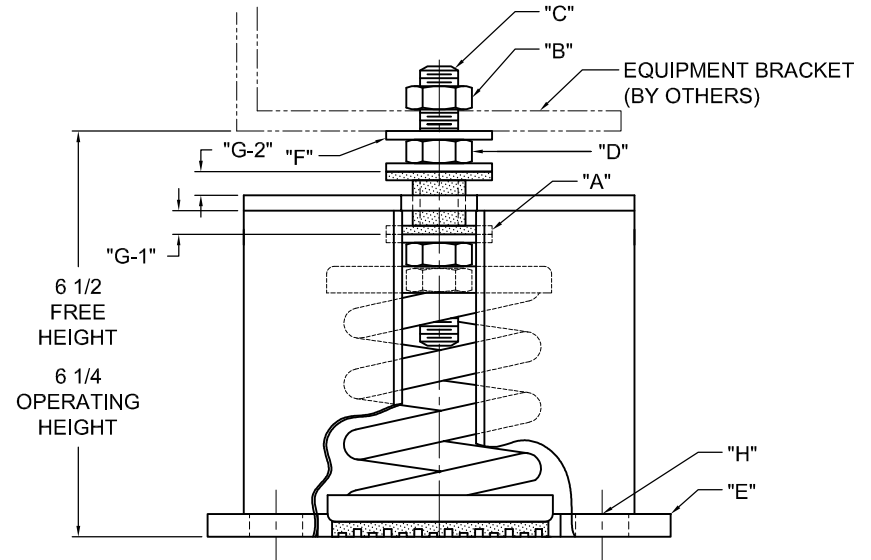

OTHER MATERIALS, COMPOUNDS, OR FINISHES WITH EQUAL OR SUPERIOR PROPERTIES MAY BE SUBSTITUTED AS THEY BECOME AVAILABLE.

CERTIFIED FOR:

JOB NAME: _____
 CUSTOMER: _____
 CUSTOMER P.O.: _____
 SALES ORDER: _____

**MODEL AMSR-1E 195-3250 LBS.
 SEISMIC ISOLATORS
 1 INCH DEFLECTION**



THE VMC GROUP
The Power of Together
 Bloomingdale, NJ 07403
 Houston, TX 77041

SCALE: NONE
 SHEET: _____



DRAWING NO.: _____ REVISION _____